

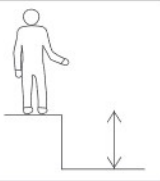

OF2-11 Triple Twister



Installation manual
Instrukcja instalacji
Manuel d'installation
Manuale di installazione
Installationshandbuch

		
0,23m	19,5 m ²	1,4m → +

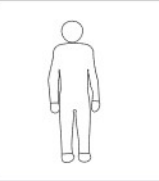
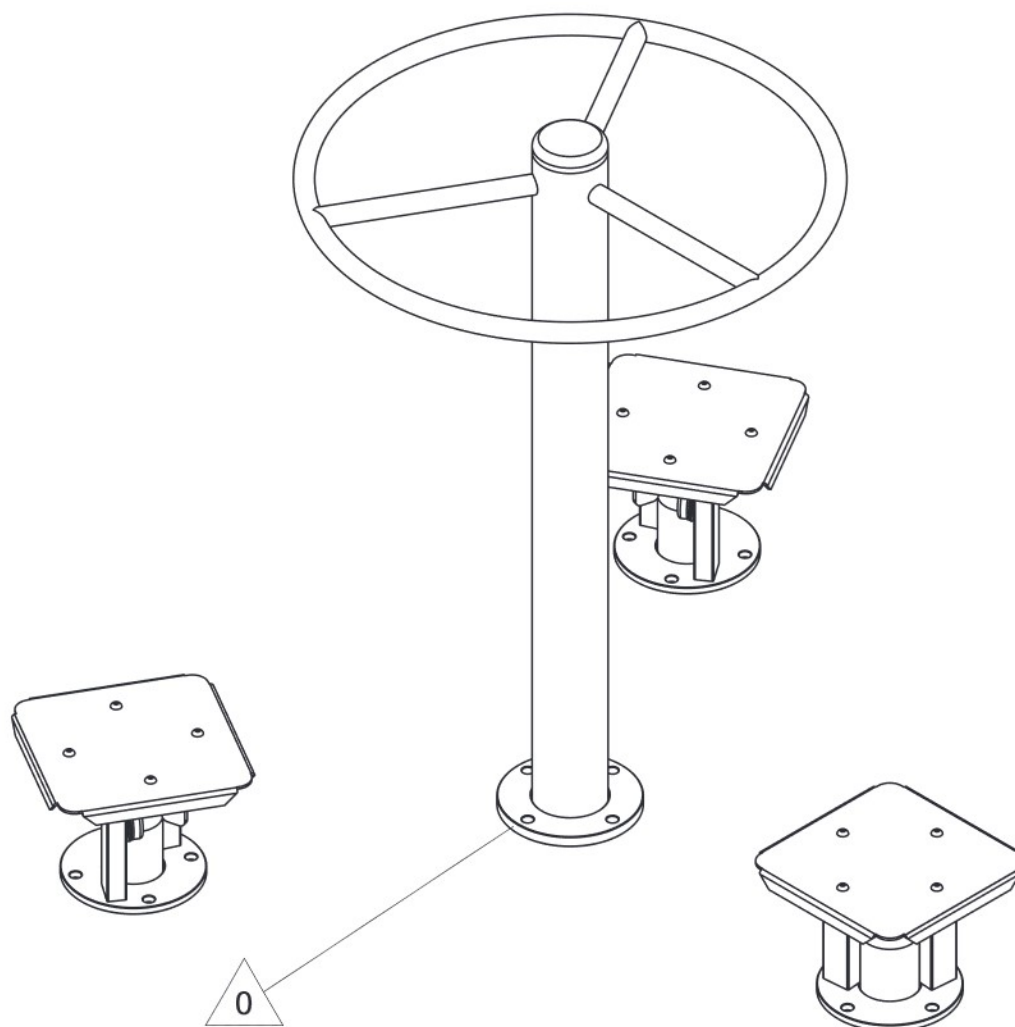

OF2-11 Triple Twister



Impact Area —
Strefa upadku
Zone d'Impact
Area de Impacto
Fallraum

Required surface: Any
Wymagana nawierzchnia: dowolna
Toute surface nécessaire
Superficiale necessaria: Qualsiasi
Erforderliche Oberflächen: Jede

19,5 m²

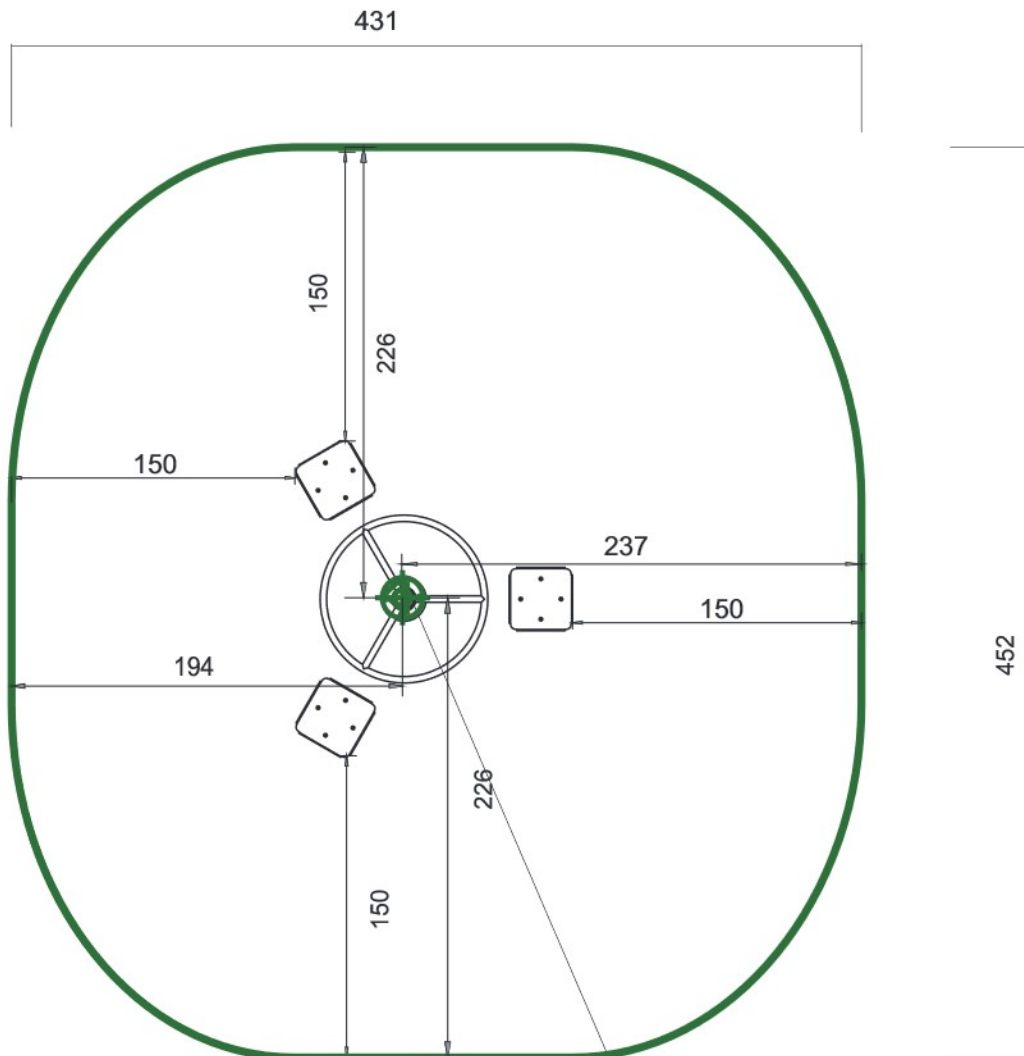

Setting Out Point
Punkt odniesienia
Point de Référence
Punto de referencia
Bezugspunkt

OF2-11 Triple Twister



Concrete pad 
Fundament betonowy
Dalle béton
Solera de Hormigón
Beton Bodenplatte

0,37 m² / 0,19 m³

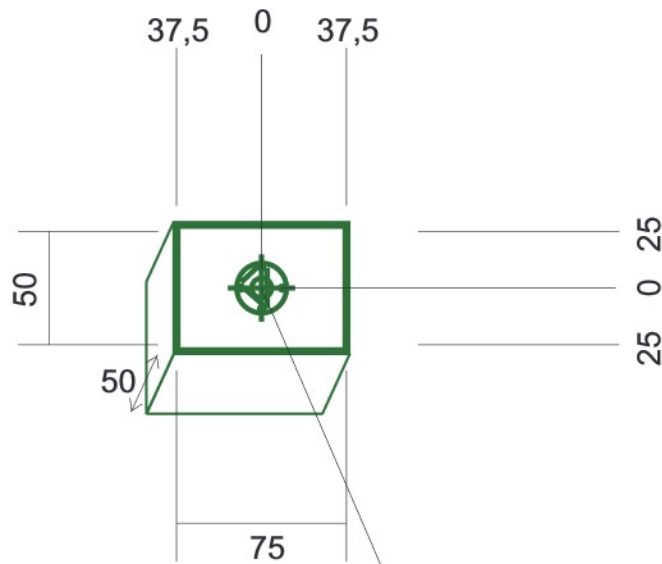







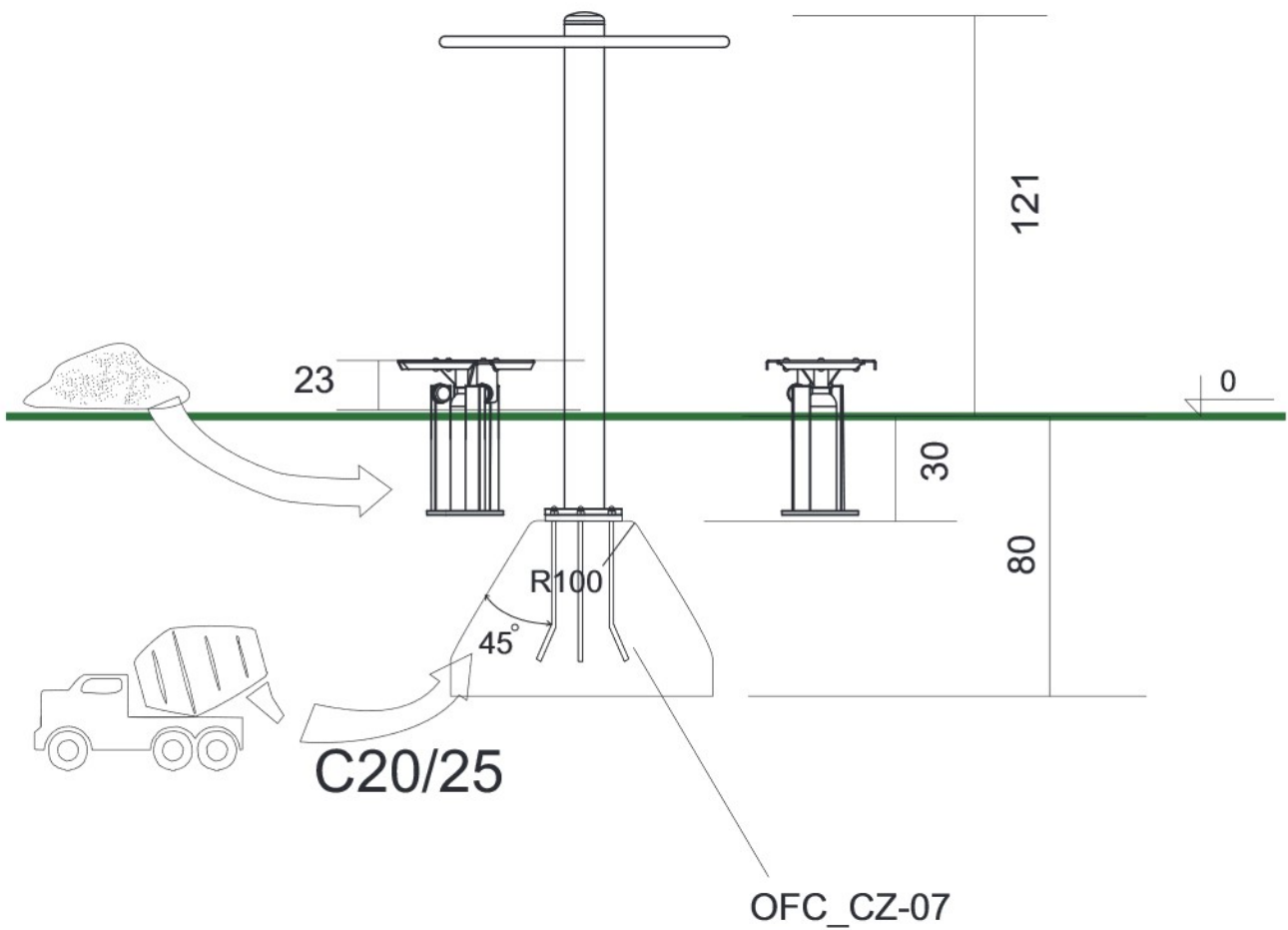

Setting Out Point
Punkt odniesienia
Point de Référence
Punto de referencia
Bezugspunkt

OF2-11 Triple Twister



Footing plan
Plan fundamentowania
Implanation
Implanación
Fundamentplan

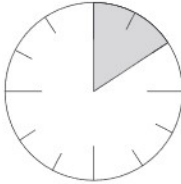

4xM16 	4xM16 	 24 	2x 		 Min. 48h
--	--	---	---	---	---