

OF3-11 Small Wheels

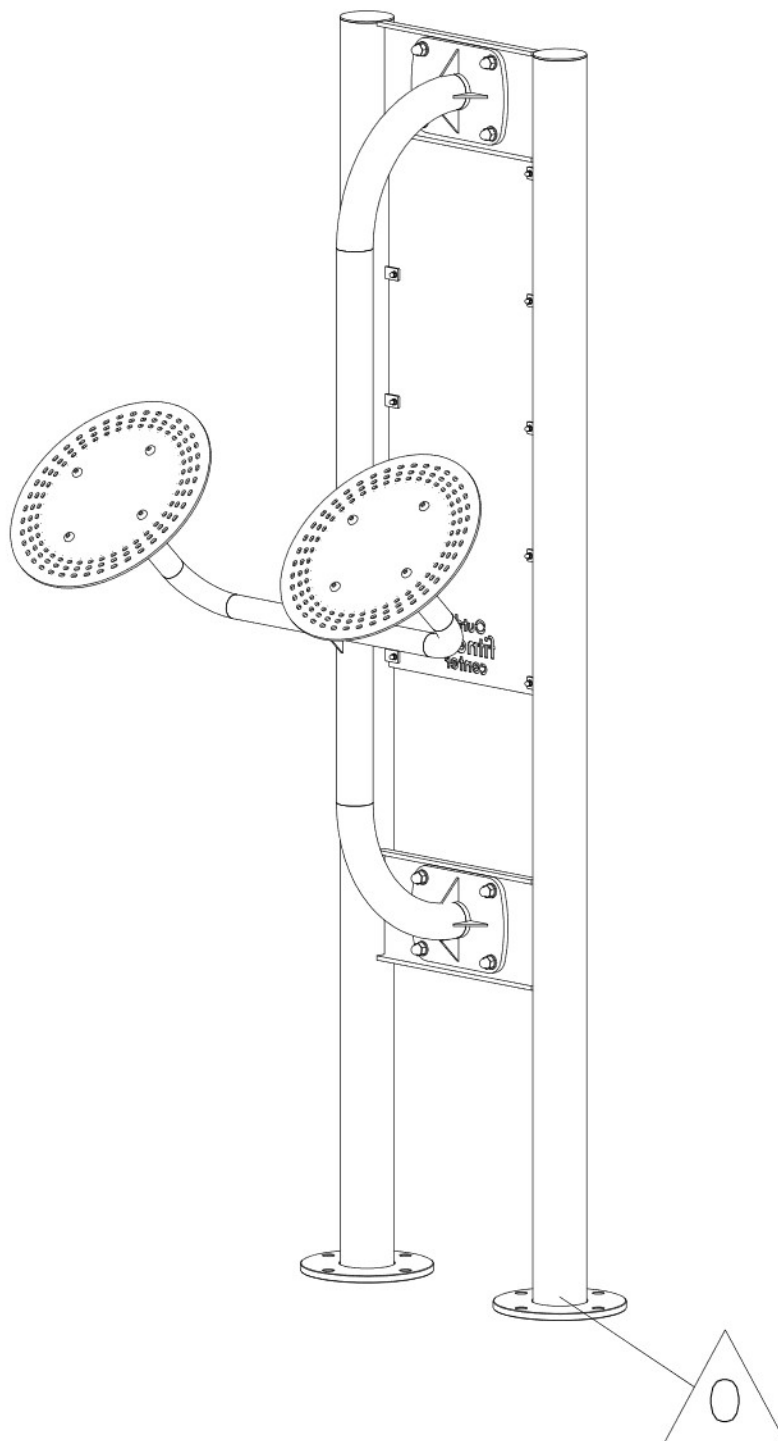

Installation manual
Instrukcja instalacji
Manuel d'installation
Manuale di installazione
Installationshandbuch

0m	14,6 m ²	1,4m → +



OF3-11 Small Wheels



Impact Area —
Strefa upadku
Zone d'Impact
Area de Impacto
Fallraum

Required surface: Any
Wymagana nawierzchnia: dowolna
Toute surface nécessaire
Superficie necessaria: Qualsiasi
Erforderliche Oberflächen: Jede

14,6 m²

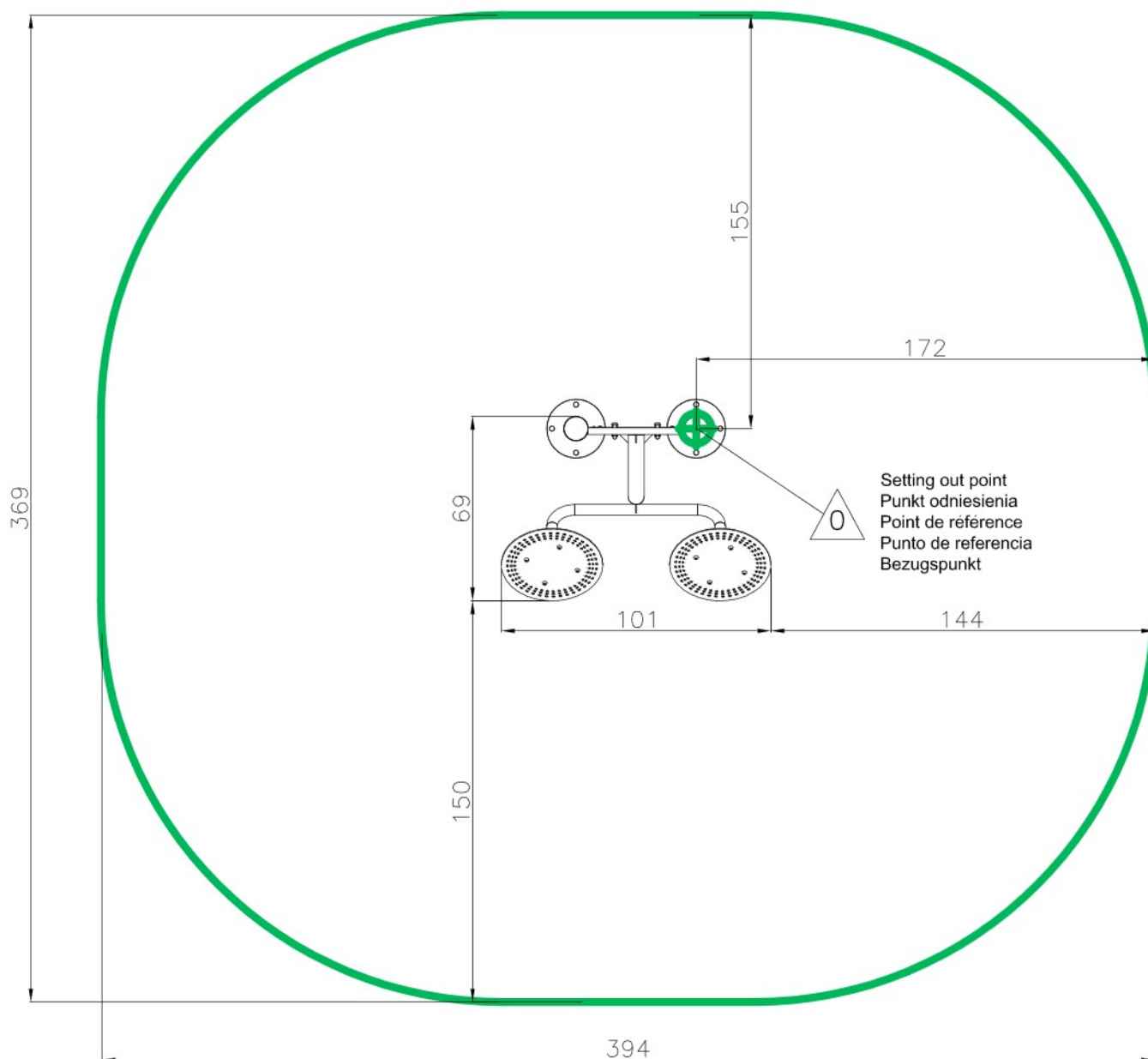

OF3-11 Small Wheels



Concrete pad 
Fundament betonowy
Dalle béton
Solera de Hormigón
Beton Bodenplatte

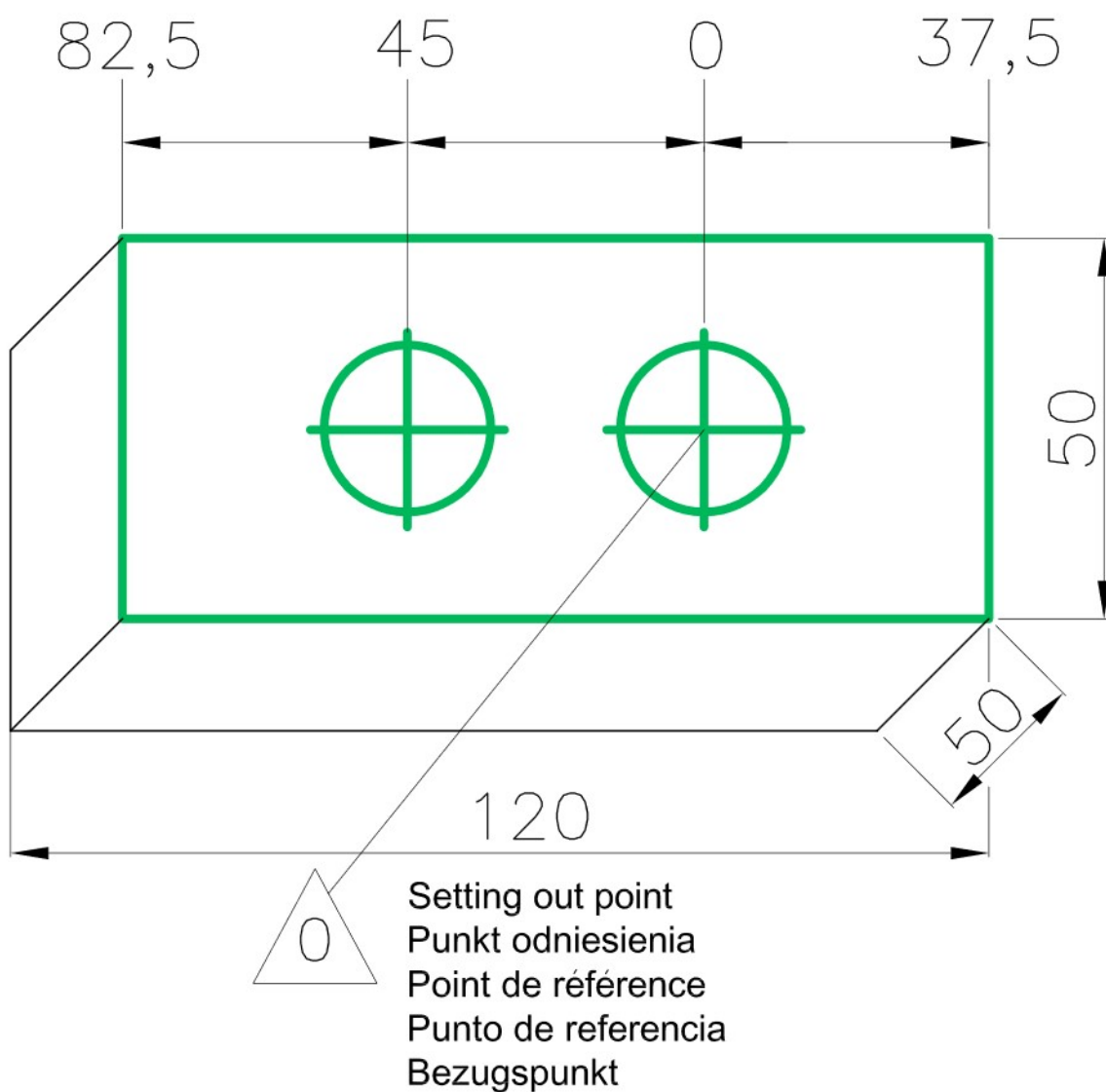

OF3-11 Small Wheels



Footing plan
 Plan fundamentowania
 Implanation
 Implanación
 Fundamentplan

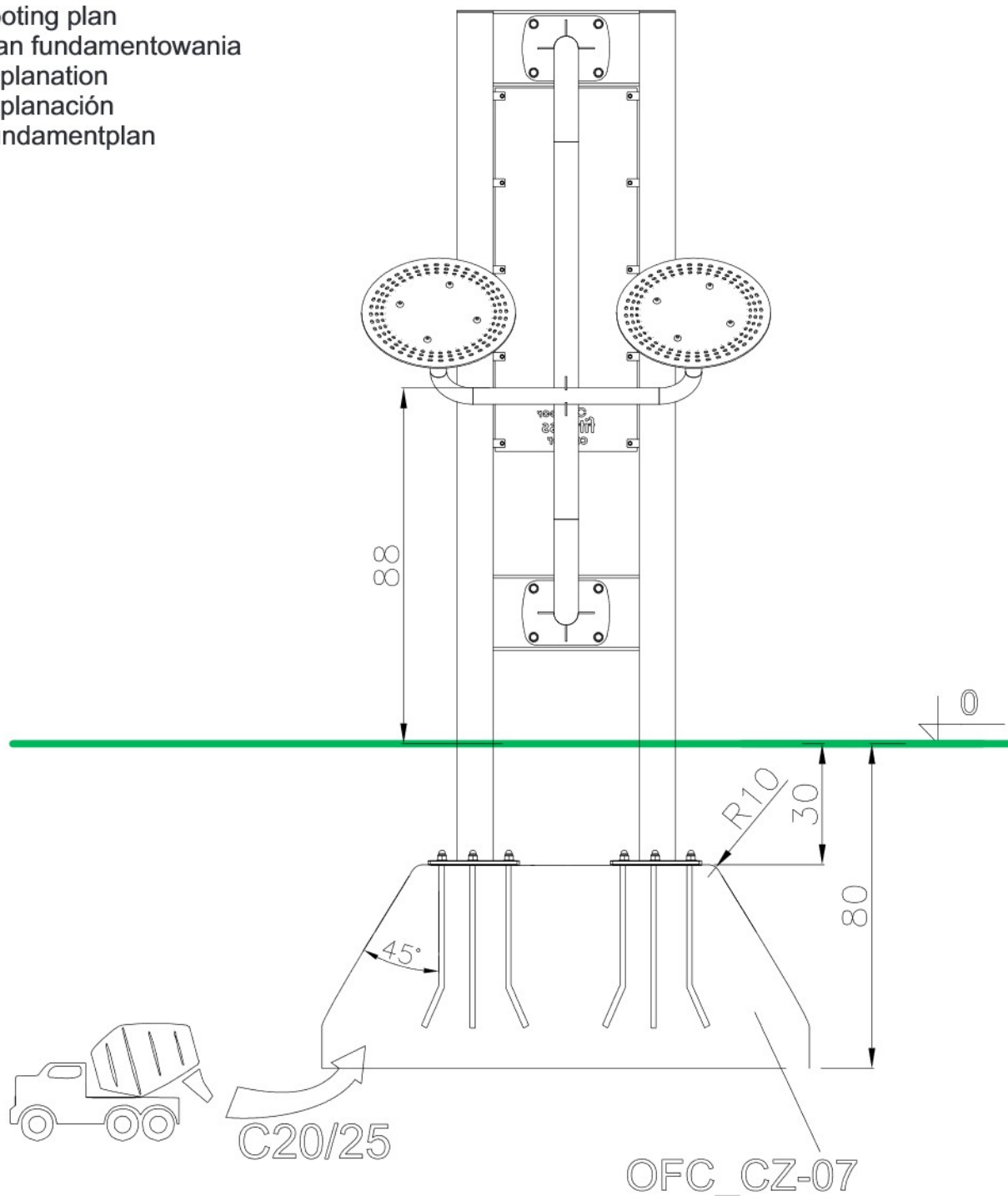

<p>4xM16</p>	<p>4xM16</p>	<p>24</p>	<p>2x</p>		<p>C20/25</p> <p>Min. 48h</p>
--------------	--------------	-----------	-----------	--	-------------------------------