

Unit Specification		
 Equipment Dimension	3.2m x 1.8m x 2.2m	 FHF
	0.9m	
 Overall Weight	184kg	 Heaviest Part
	19kg	
 Largest Part	1.8m x 0.5m x 0.5m	 Longest Part
	1.8m	
 Maximum Gradient	1 in 50	 Construction Space
	6.7m x 5.6m x 3.4m	
 Manpower Required	2	 Estimated Time
	9 hours	
 Concrete Required	0.5m ³	 Concrete Required
	0.6m ³ (Surface Fixed)	

Plastic Slide

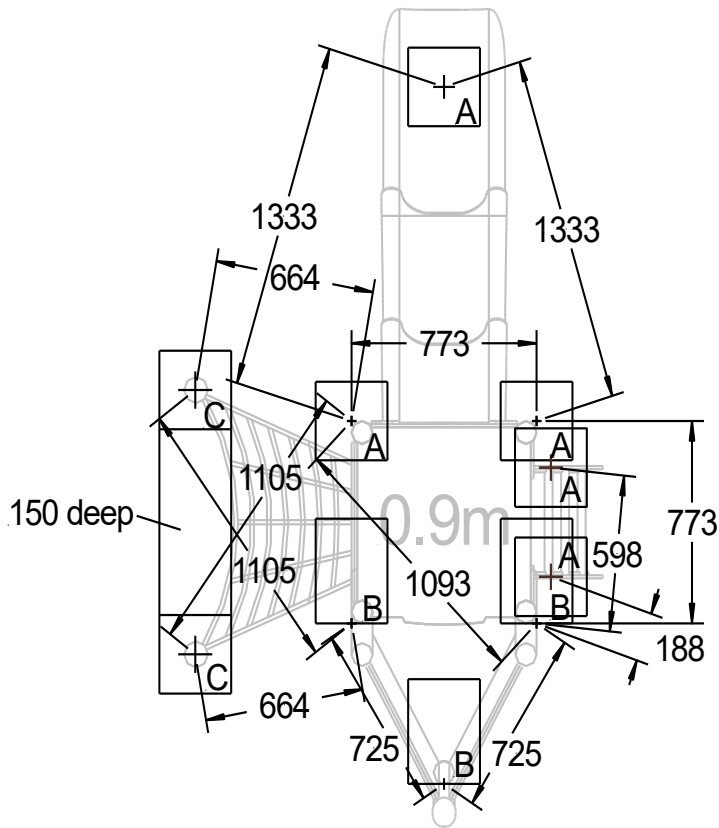

- A = 300 (w) X 300 (l) X 600 (d)
- B = 300 (w) X 400 (l) X 600 (d)
- C = 300 (w) X 300 (l) X 400 (d)

Stainless Steel Slide

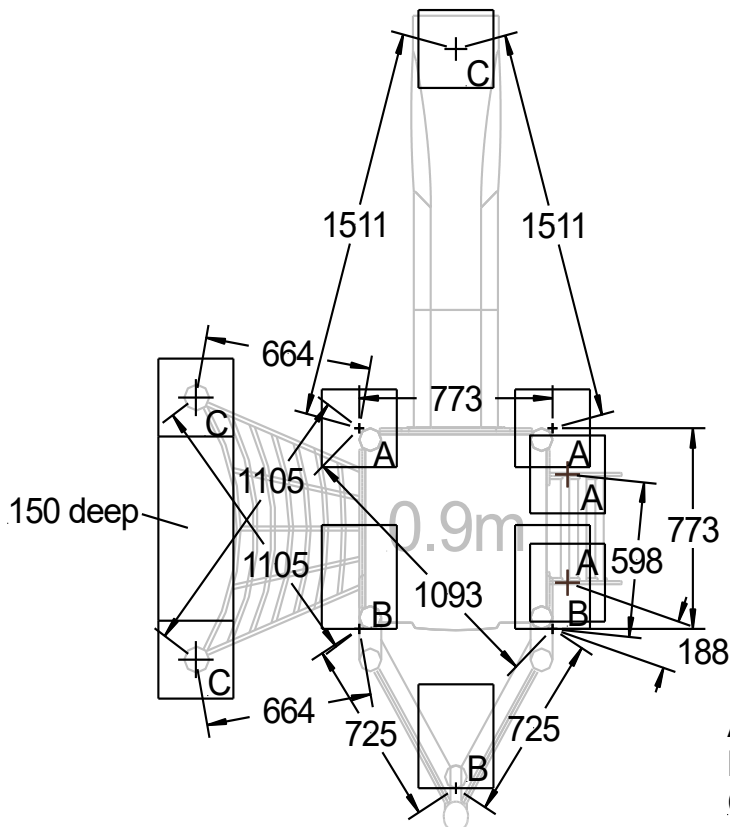

- A = 300 (w) X 300 (l) X 600 (d)
- B = 300 (w) X 400 (l) X 600 (d)
- C = 300 (w) X 300 (l) X 400 (d)

Plastic Slide

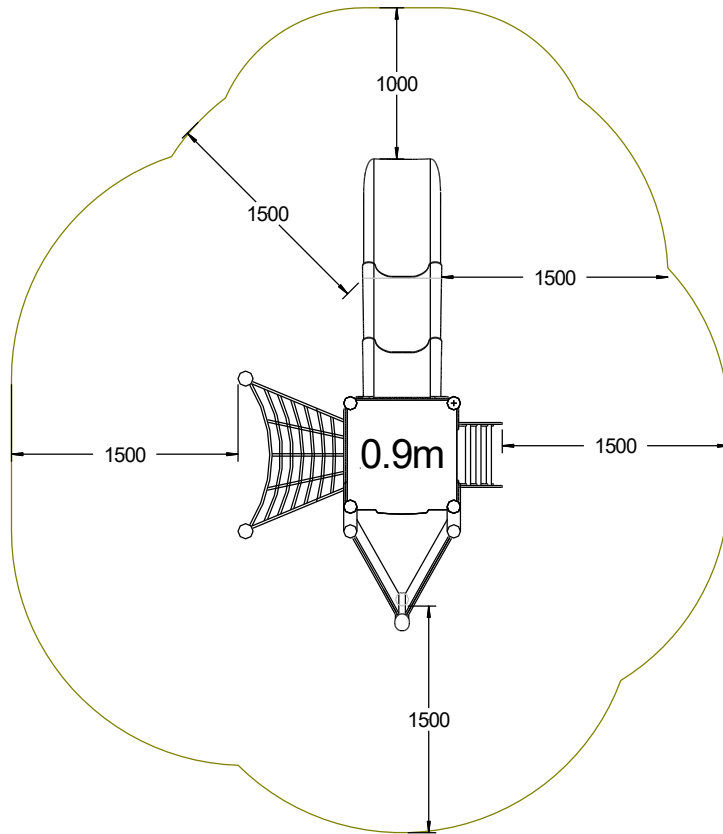

Stainless

