









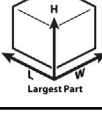
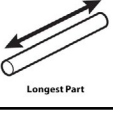
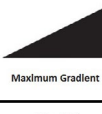

Unit Specification		
 Equipment Dimensions	4.9m x 1.8m x 2.9m	 FHF
	1.1m	
 Overall Weight	294kg	 Heaviest Part
	32kg	
 Largest Part	2.4m x 0.6m x 0.5m	 Longest Part
	2.9m	
 Maximum Gradient	1 in 50	 Construction Space
	6.9m x 3.8m x 4.9m	
 Manpower Required	2	 Estimated Time
	13 Hours	
 Concrete Required	0.6m3 SGF	 Concrete Required
	N/A	

## Standard Foundation Plan - Plastic Slide



## Standard Foundation Plan - Stainless Steel Slide

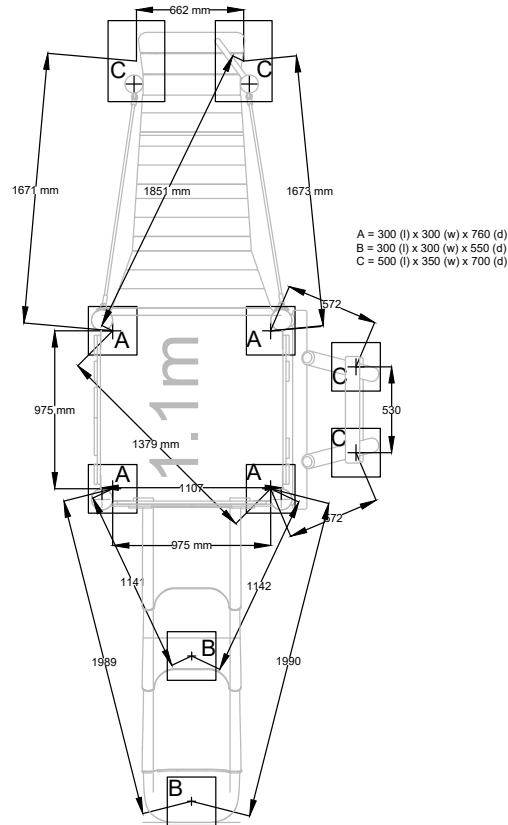
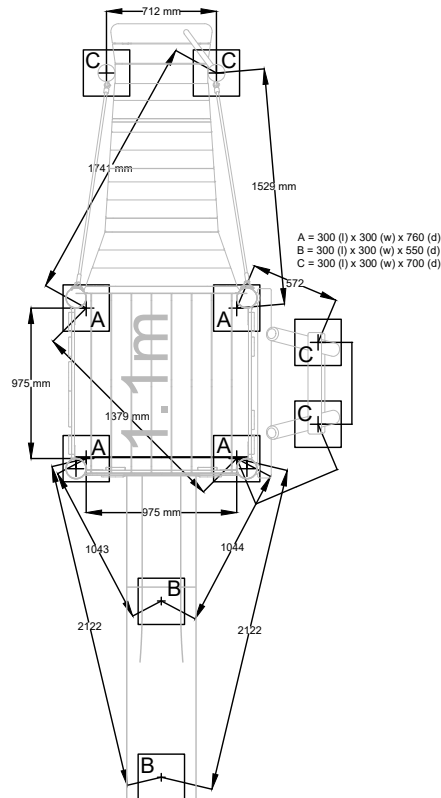

## BS EN 1176 Impact Area - Plastic Slide

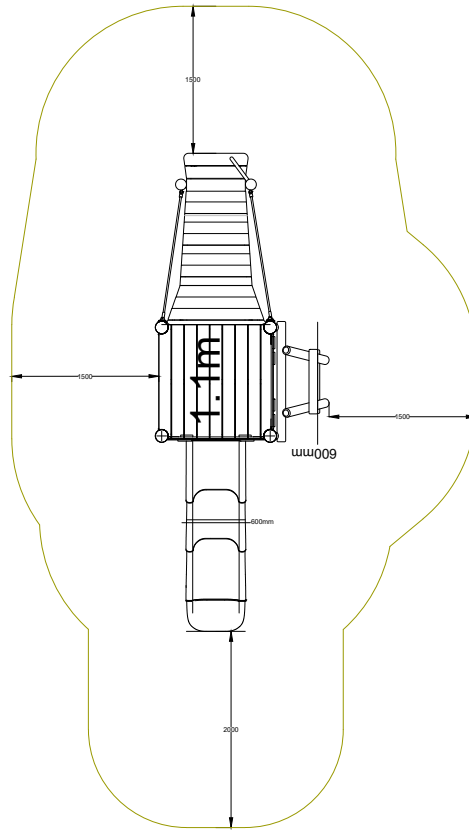

## BS EN 1176 Impact Area - Stainless Steel Slide

