

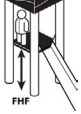









Unit Specification		
 Equipment Dimensions	6.7m x 4.4m x 3.3m	 FHF
	1.5m	
 Overall Weight	561kg	 Heaviest Part
	59kg	
 Largest Part	3.5m x 1.2m x 1m	 Longest Part
	3.5m	
 Maximum Gradient	1 in 50	 Construction Space
	8.7m x 6.4m x 5.3m	
 Manpower Required	2	 Estimated Time
	20 Hours	
 Concrete Required	0.8m3 SGF	 Concrete Required
	N/A	

## Standard Foundation Plan - Plastic Slide

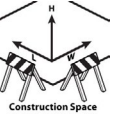

## Standard Foundation Plan - Stainless Steel Slide

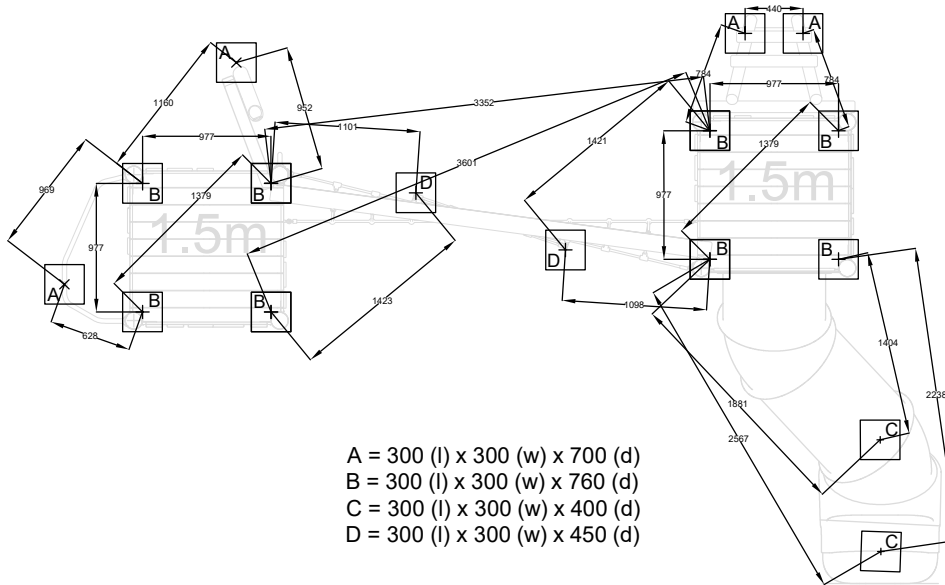
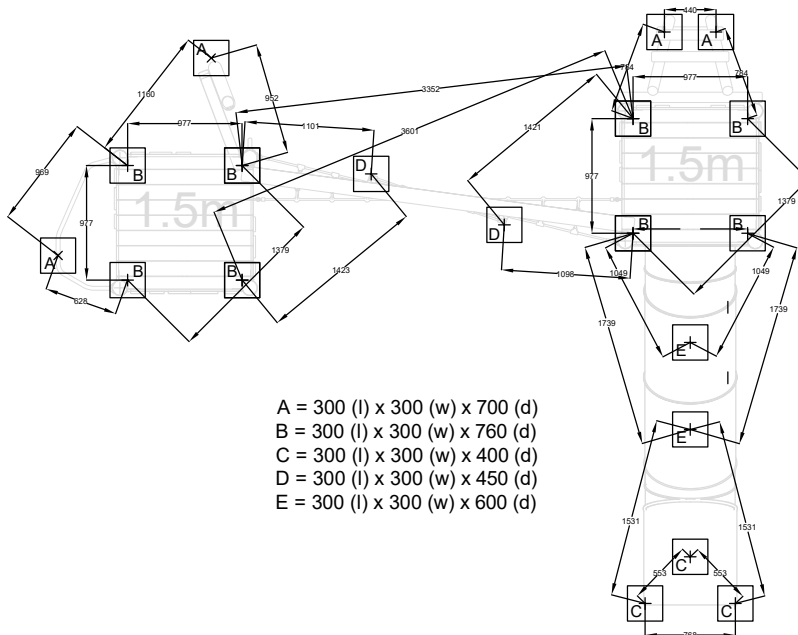

## BS EN 1176 Impact Area - Plastic Slide

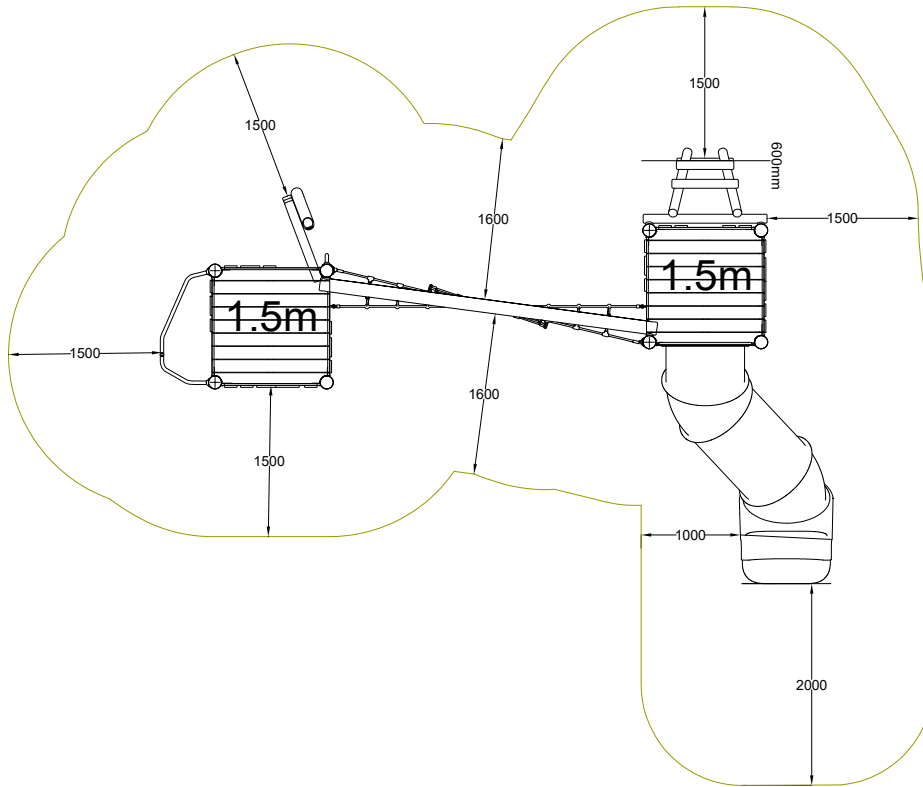

## BS EN 1176 Impact Area - Stainless Steel Slide

