

2451

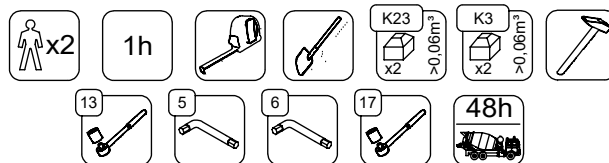

v011
17.11.2025
D.L.
[cm]

vinci
play

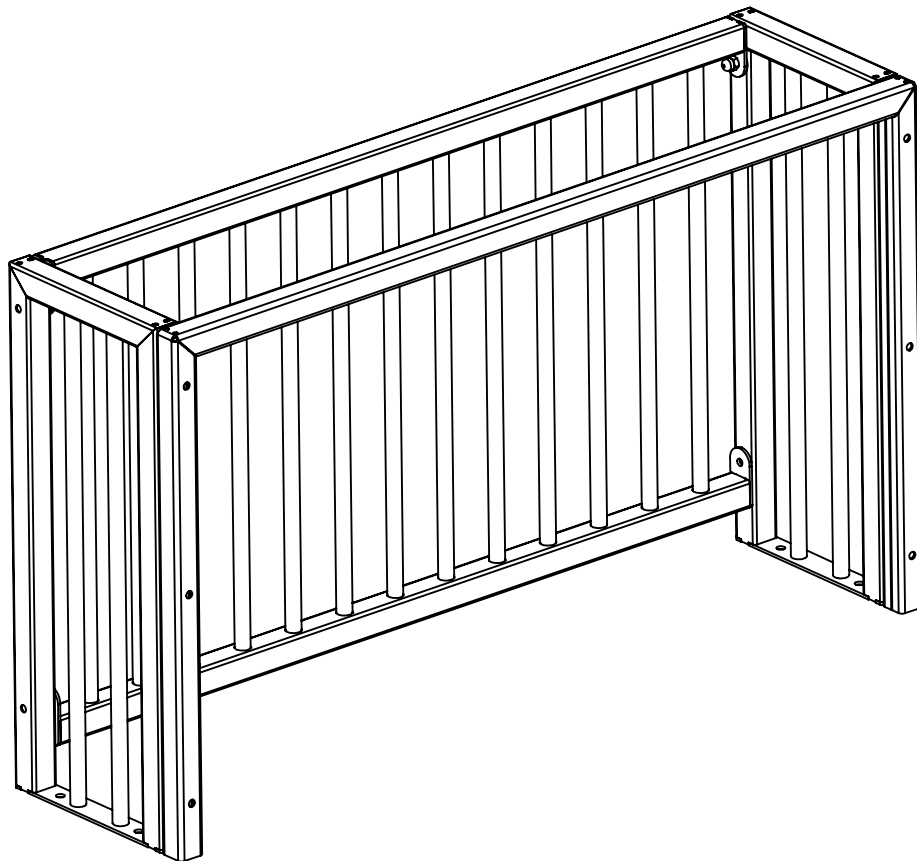
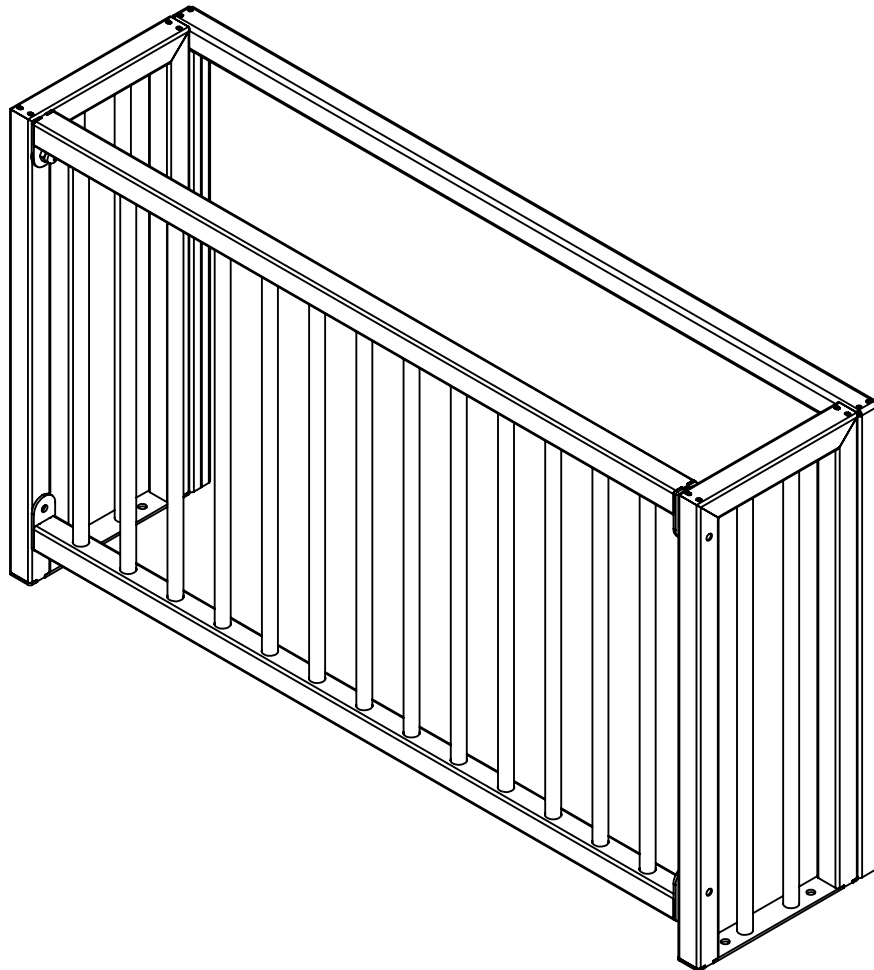
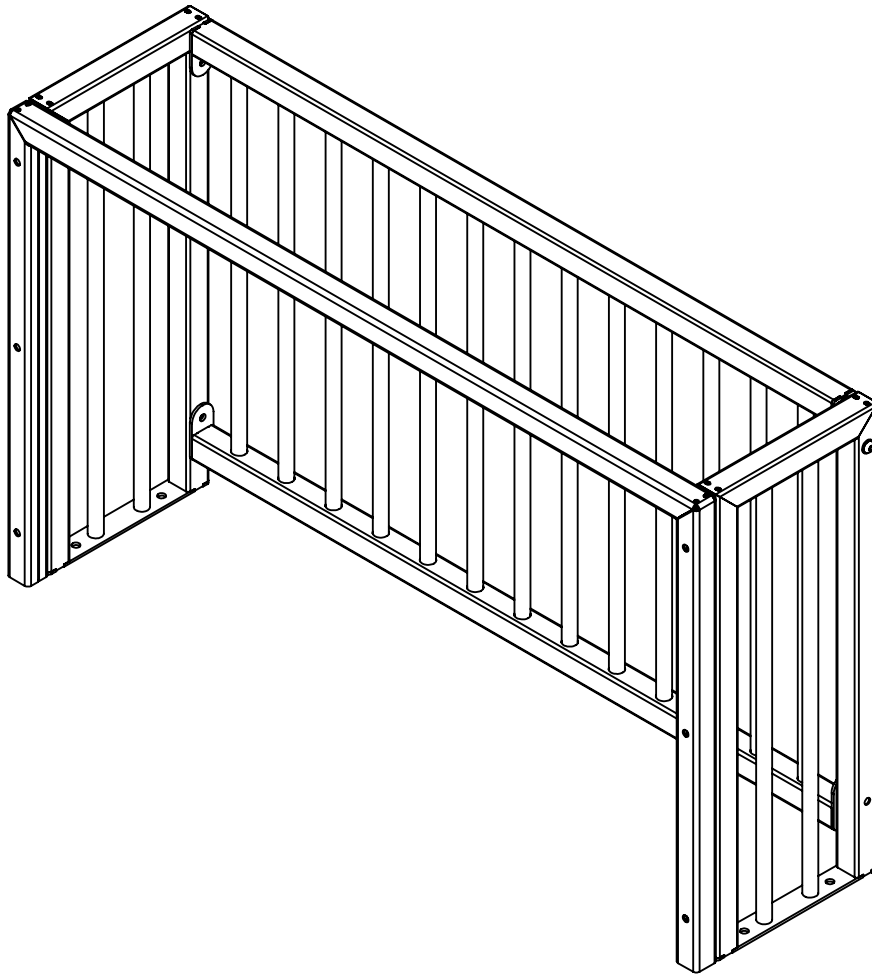

[cm]

vinci
play

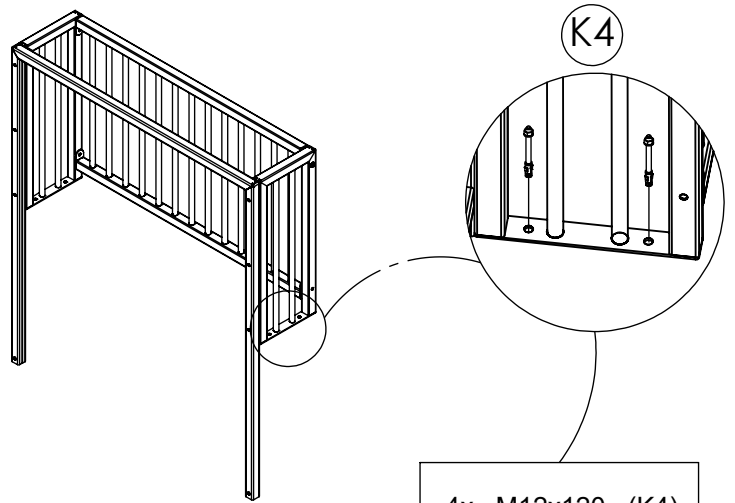
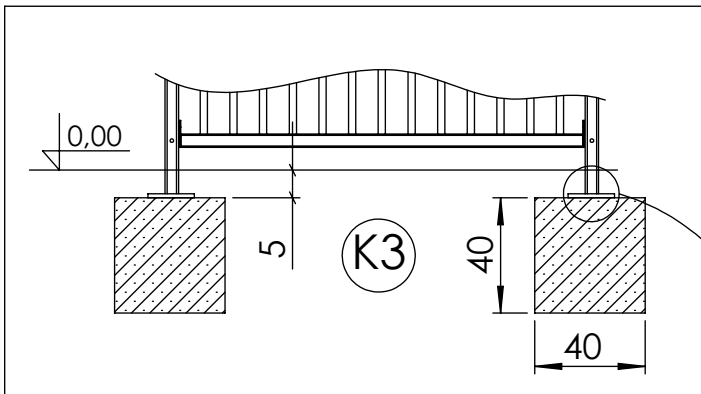
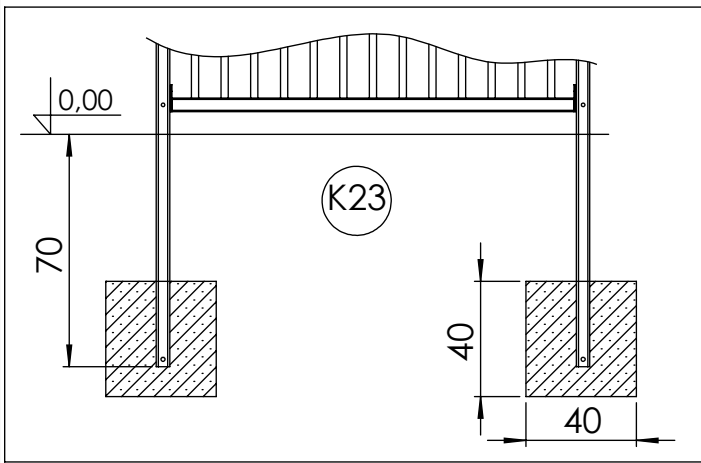
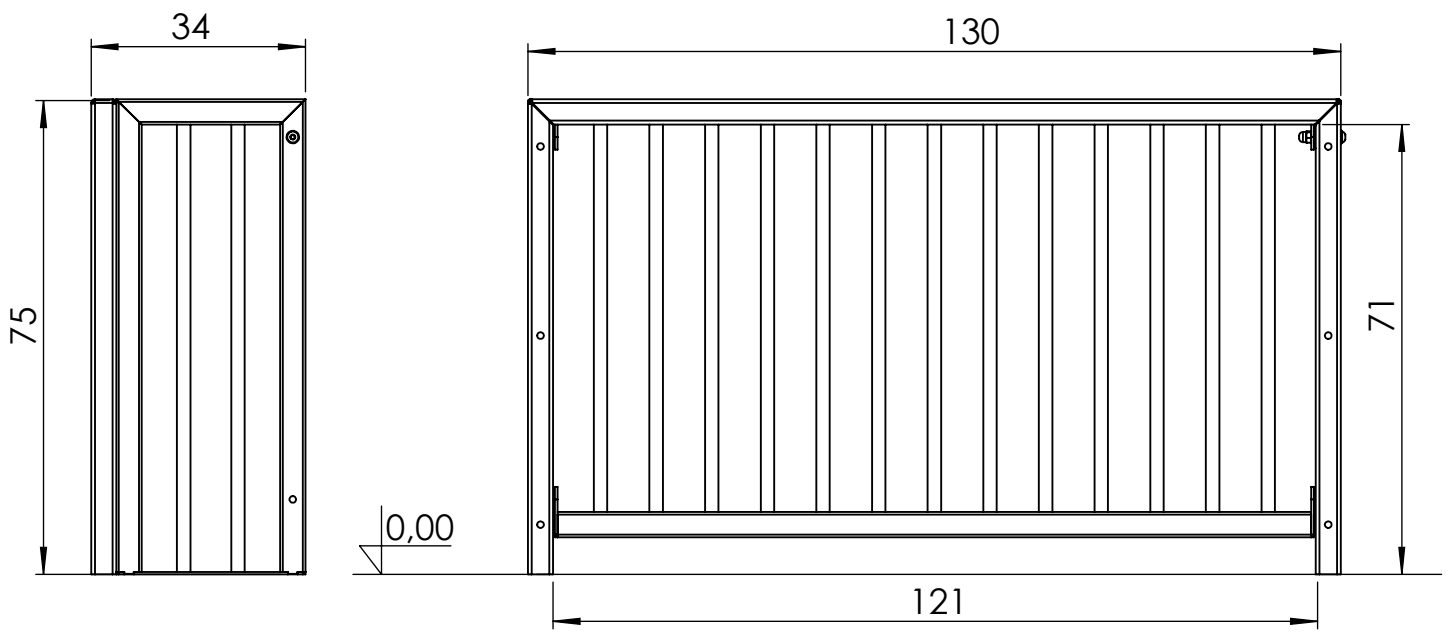

4x M12x120 (K4)

NOT INCLUDED

4x M12x120 (K3)

NOT INCLUDED

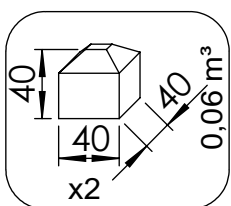

[cm]

vinci
play

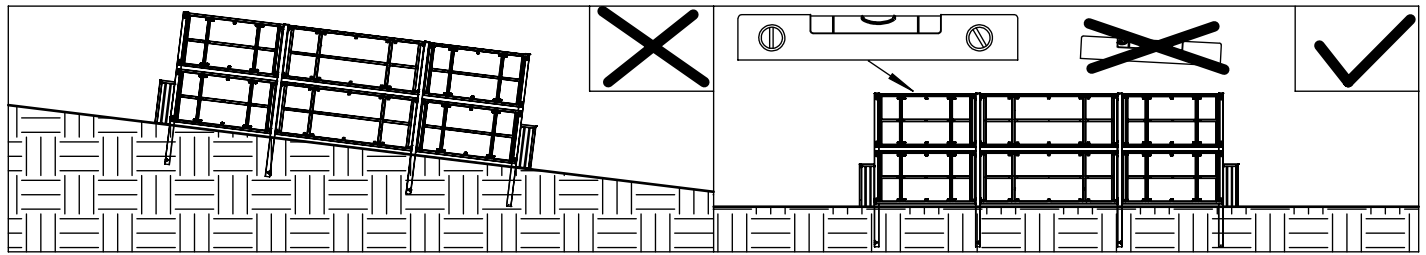
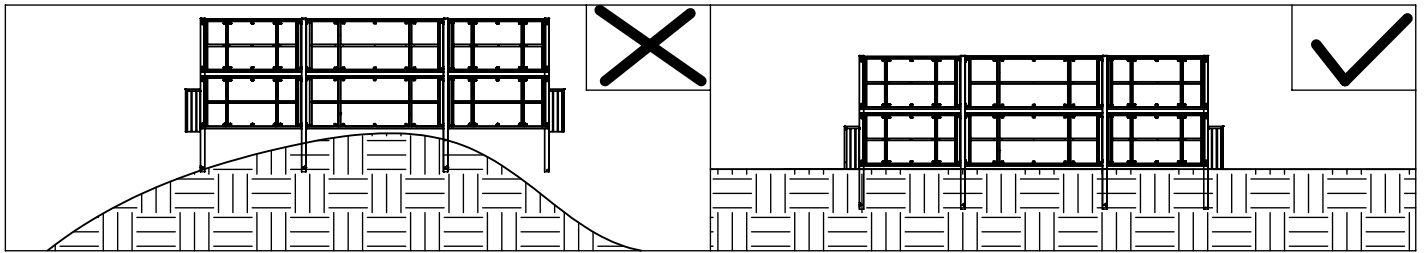

K23

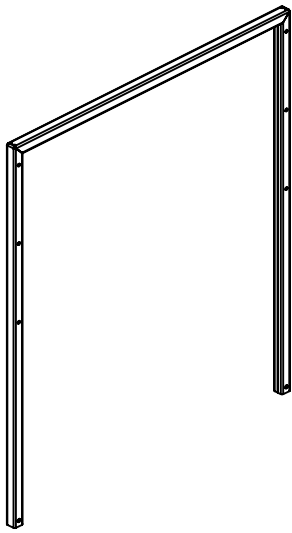

243209
x1

K3

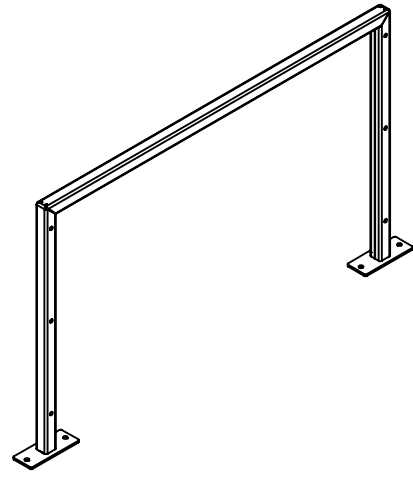

243209
x1

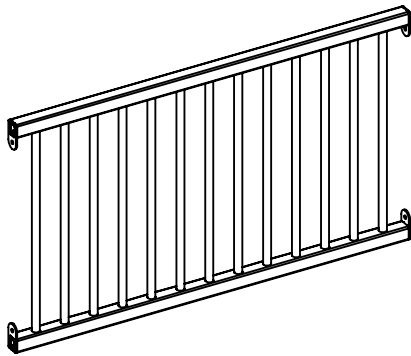

242106
x1

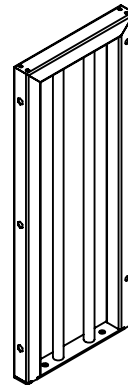

242105
x2

6x	M10x60
6x	D10pp
1x	24e002
1x	V003

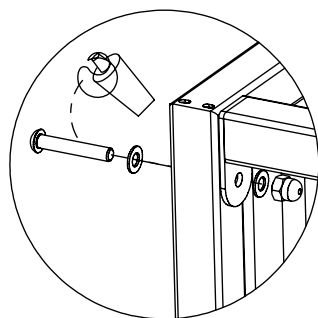

1x 24e002

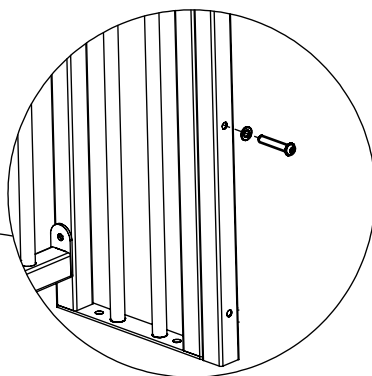
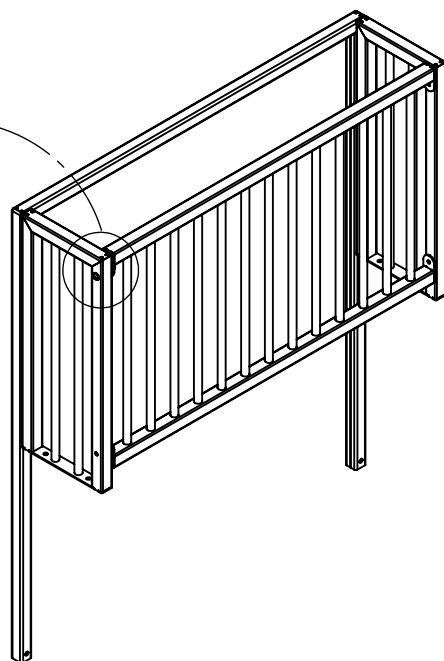
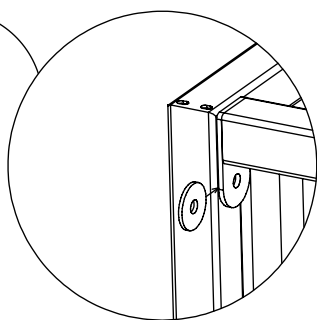

6x M10x60

6x D10 pp

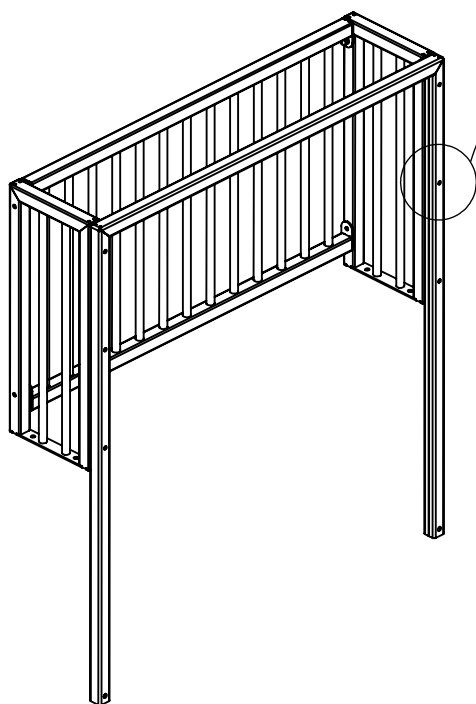

[cm]

vinci
play

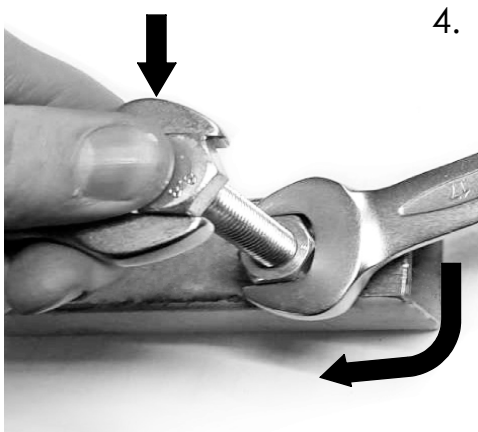
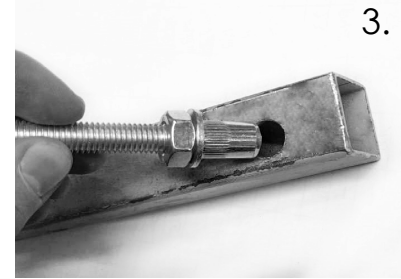
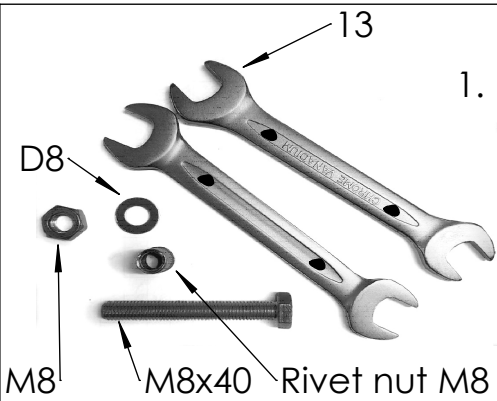
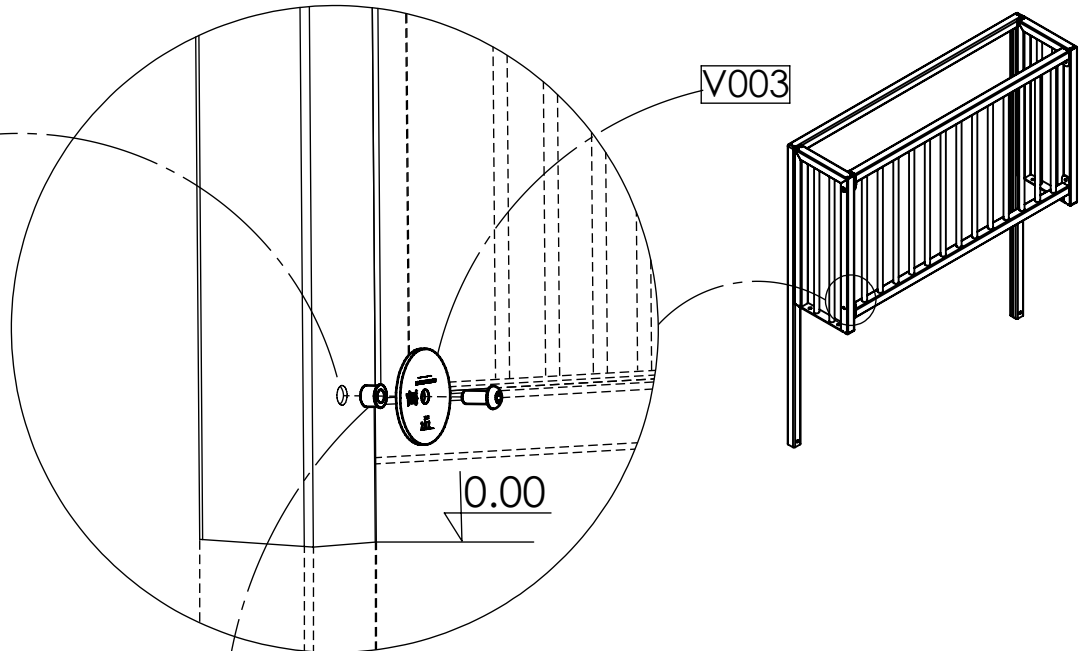
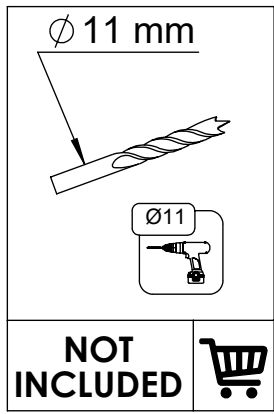

Keep the head of the screw still (it can not rotate!)
 - then by using short wrench - rotate/screw only the bottom part of solution - the nur. Attention!
 - do not put much power for this operation (otherwise the rivet nut will be damaged!).
 The difference between screw head and the nut should change from 3mm to 8mm

After that unscrew screws

Final effect

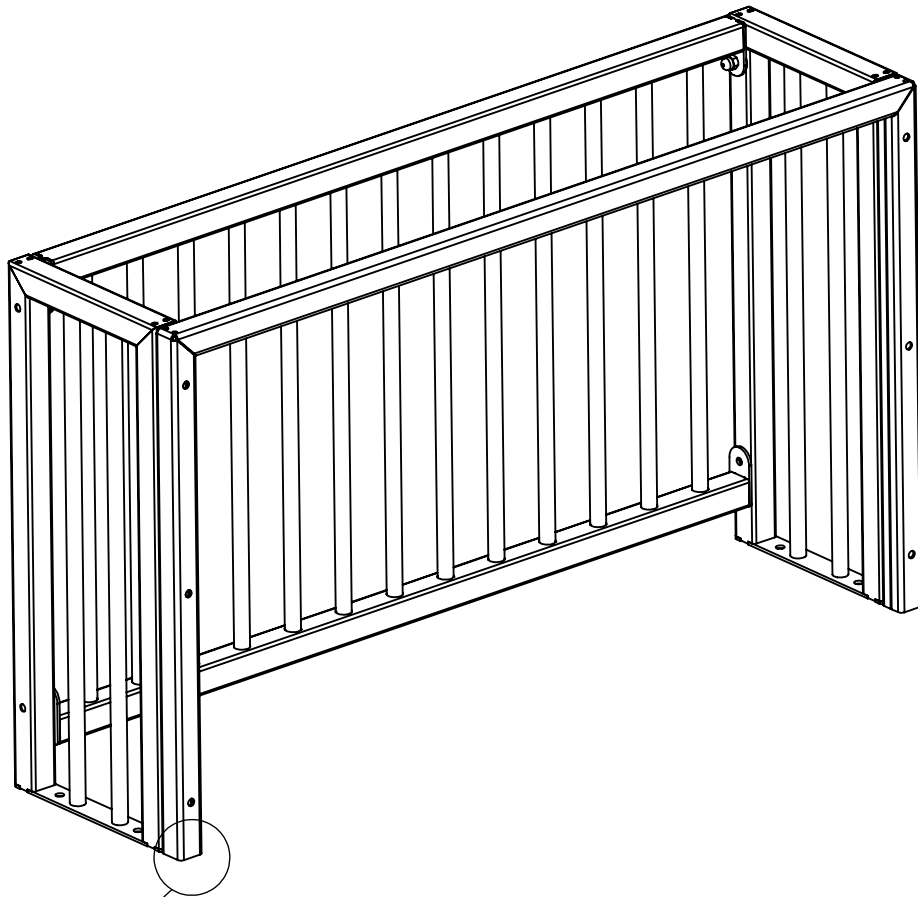
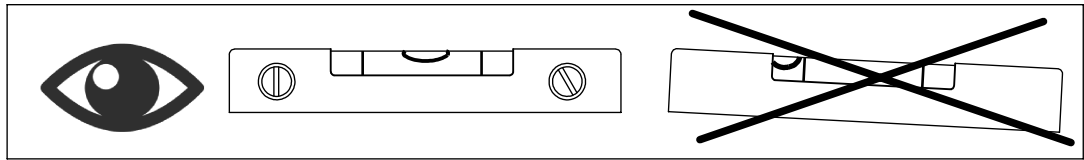

K23

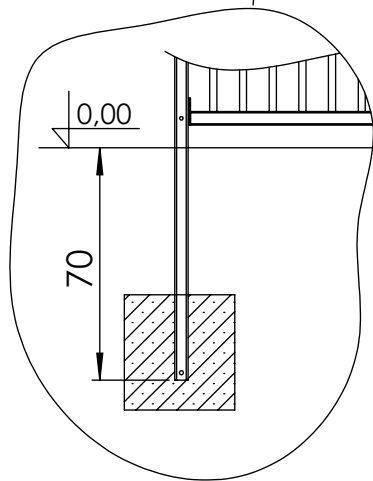

K3

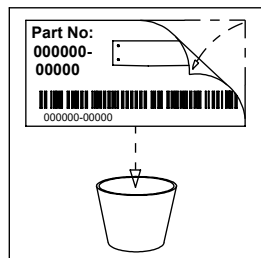
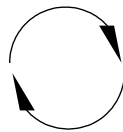
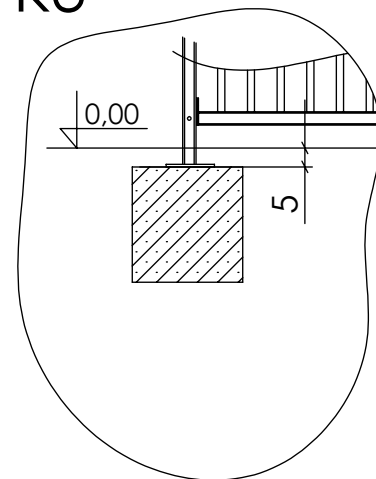

[cm]

vinci play